**DESCRIPTION**

The Altec 902-8B High Frequency Driver Loudspeakers are designed for professional sound applications requiring outstanding production of sound over a wide frequency range at substantial power levels. Such conditions are fulfilled with high efficiency and uniform response from 500 Hz to 20,000 Hz.

These drivers furnish the realistic sound production demanded by theatres and music halls, portable concert sound systems and playback systems when used in conjunction with Altec 511B (500 Hz), 811B (800 Hz), or MR931-12 (1200 Hz) horns, appropriate Altec dividing networks and Altec professional low frequency loudspeakers.

The 902-8B driver uses a voice coil of 1 $\frac{3}{4}$ -inch diameter, edge wound with aluminum ribbon and coupled to an aluminum tangential diaphragm. The entire diaphragm and voice coil assembly is field replaceable; no special tools are required. The 902-8B is fitted with a loading cap to permit operation at crossover frequencies from 500 Hz to 1200 Hz.

Altec's new Tangerine® radial phase plug* refines the technology of proper phasing, ensuring maximum high frequency reproduction while maintaining smooth overall response.

The driver is capable of uniform, peak-free reproduction throughout the range of human hearing.

SPECIFICATIONS

Power Capacity:	10 watts continuous pink noise from 500 Hz to 20 kHz. Measurements made on Altec 511B horn.
Frequency Response:	500 Hz to 20 kHz
Pressure Sensitivity:	104 dB SPL measured 4' from mouth of Altec 511B horn with 1 watt input of pink noise, band limited from 1200 Hz-5000 Hz
Minimum Impedance:	8 ohms
Construction:	
Magnet—	Ferrite, 40 ounces
Flux Density—	18,000 gauss
Magnetic Structure Weight—	5 $\frac{3}{4}$ lbs. (2.61 kg)
Diaphragm—	Aluminum tangential
Voice Coil—	Edgewound aluminum ribbon
Dimensions:	5 $\frac{1}{2}$ " (13.97 cm) diameter 2 $\frac{5}{8}$ " (6.67 cm) deep, less mounting studs
Weight:	6 lbs., 6 oz. (2.90 kg)
Finish:	Gray "Hammertone" enamel with black rubber boot
Mounting Data:	Two $\frac{1}{4}$ "-24 x 1" studs, 180° apart on 1 $\frac{1}{2}$ " centers

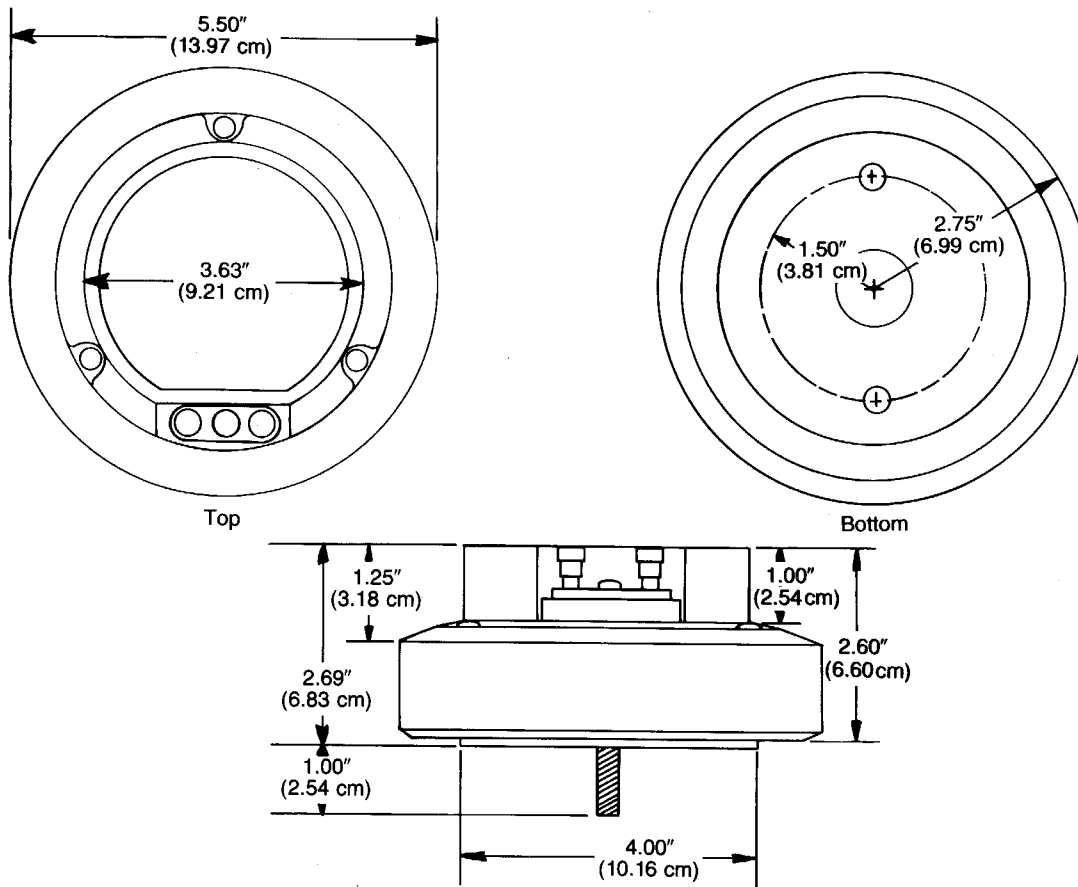

ARCHITECT'S AND ENGINEER'S SPECIFICATIONS

The compression driver loudspeaker shall meet the following criteria. Power capacity; 10 watts continuous pink noise, band-limited from 500 to 20 kHz measured on Altec 511B horn. Frequency response, uniform from 500 Hz to 20 kHz. Pressure sensitivity; 104 dB SPL measured at 4' from mouth of Altec 511B horn with 1 watt input of pink noise, band-limited from 1200 Hz to 5 kHz. The voice coil shall be of edgewound aluminum ribbon and shall operate in a magnetic gap having a flux density of 18,000 gauss derived from a 40-ounce ferrite magnet. The diaphragm shall be an aluminum tangential. A Tangerine® phasing plug with 13 radial acoustic slots shall be utilized to provide the proper phase relation-

ship between the sound emanating from the center and edges of the diaphragm and voice coil assembly. The entire diaphragm and voice coil assembly shall be field replaceable without requiring special tools or skills. The driver shall be 5½" in diameter by 2⅝" deep (excluding 1" depth of mounting studs), and shall weigh 6 pounds, 6 ounces.

The driver shall have a minimum impedance of 8 ohms and shall operate at crossover frequencies of 500 Hz, 800 Hz, 1200 Hz, or higher.

The compression driver loudspeaker shall be the Altec Model 902-8B.



1515 SOUTH MANCHESTER AVENUE, ANAHEIM, CALIFORNIA 92803
ALTEC CORPORATION